

Introduction

Intersil's NOVRAM (Nonvolatile RAM) devices are high-speed SRAMs overlaid bit-for-bit with a nonvolatile E²PROM array. The AUTOSTORE (AS) feature available on these parts automatically saves the RAM contents to E²PROM during power-down. AS typically requires some basic V_{CC} holdup circuitry to ensure successful completion.

Basic Autostore Circuit

The minimal components necessary to achieve an AS are a capacitor and diode which connect to the NOVRAM as shown in Figure 1. The "hold-up" capacitor must be capable of supplying the maximum AS current (I_{CC3 max.}) for the maximum AS period (T_{ASTO max.}) as V_{CC} falls to a level between the AS threshold voltage (V_{ASTH min.}) and the AS end voltage (V_{ASEND min.}). The "hold-up" capacitor value (C_H) is calculated using the equation:

$$C_H = \frac{(I_{CC3 \max})(T_{ASTO \max})}{V_{ASTH \min} - V_{ASEND \max}}$$

and is derived by taking the integral of:

$$i = C \frac{dV}{dt}$$

To use the circuit with a 5V supply requires that diode D_H have low forward voltage drop V_F. A Schottky diode such as the 1N5817 (available from Motorola or Philips) is suitable with maximum V_F of 0.32V at 100mA. The cost of the component is around 20¢ in volume.

Power Supply Limitation

Intersil specifies a NOVRAM V_{CC} operating range between 4.5V and 5.5V. The diode in the AS circuit, however, results in a voltage drop (V_F) between the power supply and the NOVRAM's V_{CC} pin. A maximum V_F of 0.32V results in a possible AS at a supply voltage of 4.62V. For a reasonable margin of safety, the suggested AS circuit should be powered using a supply that operates above 4.75V. A 5V ±5% power supply would be one way of ensuring correct AS operation.

TABLE 1. NOVRAM AUTOSTORE DEVICE SUMMARY

Part No.	Min	V _{ASTH} (V)	Max	V _{ASEND} (V)	T _{ASTO} (ms)	I _{CC3} (mA)	C _H (μF)
				Min	Max	Max	Min
X24C45	4.0		4.3	3.5	5.0	2.0	20
X20C16	4.0		4.3	3.5	2.5	2.5	13

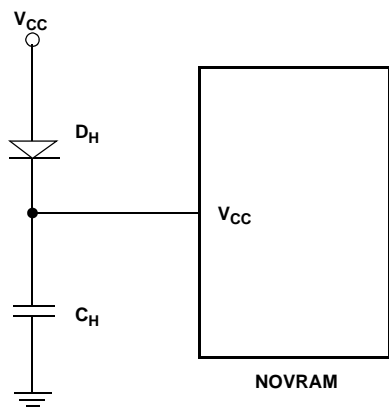

FIGURE 1

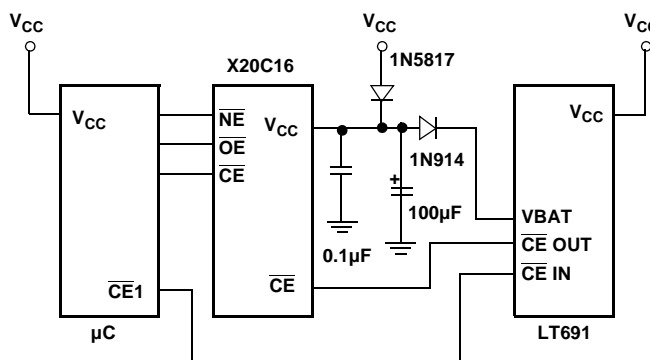

FIGURE 2

Pre-AUTOSTORE Data Corruption

If the supply to a microcontroller interfacing to a parallel NOVRAM is lost while the NOVRAM remains powered, inadvertent writes to the SRAM can occur. The uncertain state of the microcontroller control lines during power-down may cause fluctuations in the status of CE, WE, and OE, which can result in a write condition. Invalid SRAM data may be transferred to the nonvolatile E²PROM array if these changes occur before an AS. These inadvertent write conditions can be avoided using supervisory ICs available from manufacturers such as Linear Technology or Maxim. These devices control the CE of the NOVRAM so that below a set supply threshold voltage, CE is held HIGH and the NOVRAM is placed into a standby condition. An example of such a circuit is shown in Figure 2.

Conclusion

NOVRAMs combine the advantages of fast access RAMs and nonvolatility for E²PROMs. The AUTOSTORE feature enables data integrity to be maintained during power-down. In most applications two additional components (a diode and capacitor) are all that is needed to ensure successful completion of an AUTOSTORE. A supervisory IC may also be useful to protect the part from inadvertent writes.